



Automatic drilling and tapping units

More mechanization in your drilling operations

Simple, cost effective. Atlas Copco automatic drilling and tapping units cut costs by reducing machining time in ancillary equipment, or in highly automated special machines. Modular designs allow the units to be easily replaced, transferred to other machines, or combined to form new special-purpose machines.

Contents	Page
Automatic drilling and tapping units.....	240
Dimension sketches	244-246

AUTOMATIC DRILLING AND TAPPING UNITS

These units are available in three sizes, LBL25, LBL35 and LBL45, each size covering a specific diameter range, totally up to 20 mm in steel.

The basic units can be fitted with different chucks, twin heads for simultaneous drilling of two holes and attachments for chip removal and tapping.

- **Highly dependable** – LBL drilling and tapping units feature quick and precise clamping, making them highly dependable.
- **Easy to build together** – Several holes can be drilled in a single operation since several of these compact units can easily be built together.
- **Low noise level** – The units have a low noise level as the exhaust air is discharged through silencers inside the protective casing.

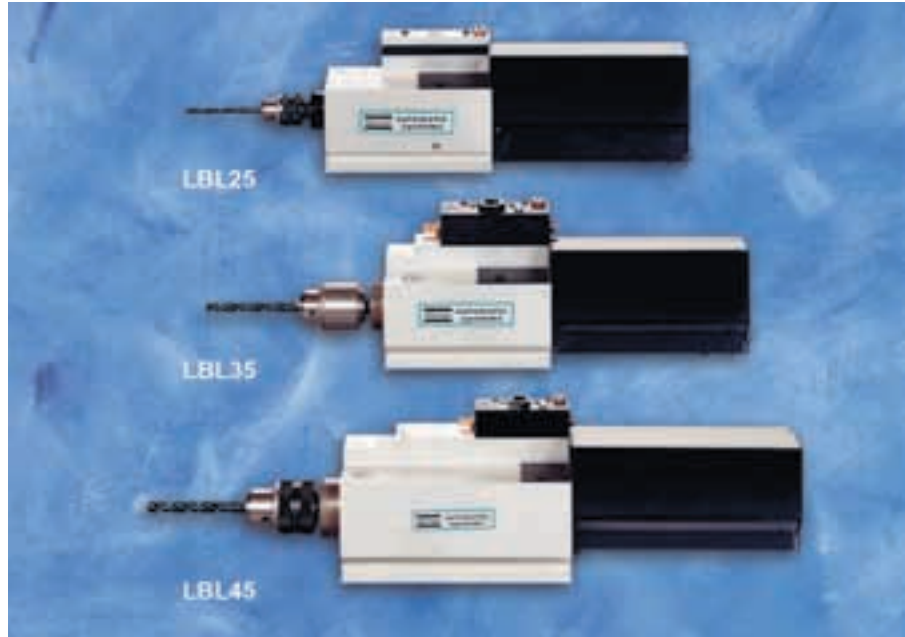

Model	Capacity		Feed force N	Max output		Feed stroke mm	Free speed r/min	Weight		Air consumption				Ordering No.
	Steel mm	Alumi- nium mm		kW	hp			kg	lb	Max output l/s	Free speed l/s	cfm	cfm	
Automatic drilling and tapping units														
LBL25E 220	1.2	2.0	350	0.22	0.3	80	21000	3	6.6	5.2	11	5.8	12	8421 9208 47
LBL25E 049	3.2	5.0	350	0.22	0.3	80	4600	3	6.6	5.2	11	5.8	12	8421 9208 55*
LBL25E 022	5.0	6.5	350	0.22	0.3	80	2100	3	6.6	5.2	11	5.8	12	8421 9208 63*
LBL25E 011	8.0	10.0	350	0.22	0.3	80	1100	3	6.6	5.2	11	5.8	12	8421 9208 71*
LBL35E 190	–	2.0	1050	0.33	0.5	80	19000	7	15.0	9.5	21	10.6	22	8421 9308 53
LBL35E 054	3.0	5.0	1050	0.33	0.5	80	5400	7	15.0	9.5	21	10.6	22	8421 9308 46*
LBL35E 030	5.0	7.0	1050	0.33	0.5	80	3000	7	15.0	9.5	21	10.6	22	8421 9308 38*
LBL35E 014	8.0 ^a	10.0 ^b	1050	0.33	0.5	80	1400	7	15.0	9.5	21	10.6	22	8421 9308 12*
LBL35E 007	11.0 ^c	13.0 ^d	1050	0.33	0.5	80	700	16	35.0	9.5	21	10.6	22	8421 9308 04*
LBL45E 025	–	10.0	2500	0.80	1.1	120	2500	16	35.0	20.0	44	9.0	19	8421 9408 52
LBL45E 015	7.0	14.0	2500	0.80	1.1	120	1500	16	35.0	20.0	44	9.0	19	8421 9408 45
LBL45E 010	10.0	16.0	2500	0.80	1.1	120	1000	16	35.0	20.0	44	9.0	19	8421 9408 37
LBL45E 007	14.0 ^c	22.0 ^d	2500	0.80	1.1	120	700	16	35.0	20.0	44	9.0	19	8421 9408 29*
LBL45E 005	16.0 ^d	22.0 ^e	2500	0.80	1.1	120	550	16	35.0	20.0	44	9.0	19	8421 9408 11
LBL45E 003	20.0 ^e	32.0 ^f	2500	0.80	1.1	120	320	16	35.0	20.0	44	9.0	19	8421 9408 03

Recommended max tapping size: ^aM4 ^bM5 ^cM8 ^dM10 ^eM12 ^fM16









* Available directly from stock.

AUTOMATIC DRILLING AND TAPPING UNITS







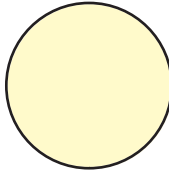
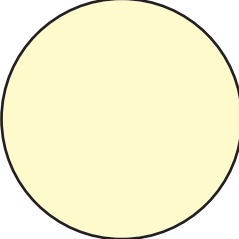



Selection guide

Steel
 Aluminium









LBL45

025	015	010	007	005	003
—	7.0	10.0	14.0 (M8)	16.0 (M10)	20.0 (M12)
					
					
10.0	14.0	16.0	22.0 (M12)	32.0 (M16)	

LBL35

190	054	030	014	007
—	3.0	5.0	8.0 (M4)	11.0 (M8)
				
				
2.0	5.0	7.0	10.0 (M5)	13.0 (M10)

LBL25

220	049	022	011
1.2	3.2	5.0	8.0
			
			
2.0	5.0	6.5	10.0



AUTOMATIC DRILLING AND TAPPING UNITS

Optional accessories

Chip removal attachments

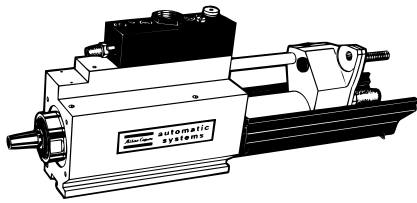

Model	Ordering No.
LBL35	4130 1950 81
LBL45	4130 1950 82

Programmed damping device

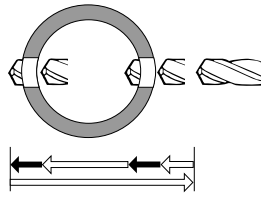

Model	Ordering No.
LBL35, -45	4130 1961 80
To be used together with the hydraulic damper.	



Hydraulic damper

LBL25

Designation	Ordering No.
Hydraulic damper (feed stroke 65 mm)	4130 1844 80
Key chuck (0-6.5 mm)	4021 0283 00
Key chuck (2-10 mm)	4021 0416 00



Key chuck

LBL35

Designation	Ordering No.
Hydraulic damper (feed stroke 65 mm)	4130 1844 80
Key chuck (2.0-13.0 mm)	4021 0452 00
Sleeve chuck (2.0-9.5 mm)	4021 0459 00
Twin spindle head, speed ratio 1:1, centre to centre adjustment range 12.7-63.5 mm	4130 1363 84
Other multiple heads on request	
Tapping unit, M2-M7	
SPD3, Taper socket J33	4130 1938 00
Holder for tapping unit SPD3	4130 1787 00
Collet 2.5-5 mm	4021 0412 00
Collet 5-6.3 mm	4021 0413 00
Tapping unit, M3-M12	
SPD5, Tapping Socket J33	4130 1939 00
Holder for tapping unit SPD5	4130 1860 00
Collet 3.3-6.8 mm	4021 0337 00
Collet 4.5-8.7 mm	4021 0336 00
Collet 6-10 mm	4021 0456 00

LBL45

Designation	Ordering No.
Hydraulic damper (feed stroke 110 mm)	4130 1895 80
Key chuck (3.2-16.0 mm)	4021 0423 00
Sleeve chuck (2.0-9.5 mm)	4021 0458 00
No. 2 Morse taper socket	4130 1080 00
No. 3 Morse taper socket	4130 1079 00
Twin spindle head, speed ratio 1:1, centre to centre adjustment range 19-95 mm	4130 1364 82
Other multiple heads on request	
Tapping unit, M15-M18	
SPD7, Taper socket, J3	4130 1940 00
Holder for tapping unit SPD7	4130 1773 00
Collet 6-10 mm	4023 1059 00



Sleeve chuck



Morse taper socket



Tapping unit



Twin spindle head

AUTOMATIC DRILLING AND TAPPING UNITS

Accessories

Collets for Twin head LBL35

Size mm	Ordering No.	Size mm	Ordering No.
2.1	4130 1367 11	5.0	4130 1367 40
2.3	13	5.1	41
2.5	15	5.2	42
		5.3	43
3.0	4130 1367 20	5.4	44
3.1	21		
3.2	22	6.0	4130 1367 50
3.5	25	6.2	52
3.8	28	6.4	54
3.9	29	6.5	55
4.0	4130 1367 30		
4.1	31		
4.5	35		

Collets for Sleeve chuck LBL35/45 Twin head LBL45

Size mm	Ordering No.	Size mm	Ordering No.
2.0	4130 1561 00.	5.4	34
2.2	02	5.5	35
2.5	05	5.8	38
		5.9	39
3.0	4130 1561 10	6.0	4130 1561 40
3.2	12	6.2	42
3.5	15	6.4	44
3.6	16	6.5	45
3.7	17	6.7	47
4.0	4130 1561 20	6.9	49
4.2	22		
4.5	25	7.0	4130 1561 50
4.6	26	7.5	55
4.9	29	8.0	4130 1561 60
		8.5	65
5.0	4130 1561 30	9.0	4130 1561 70
5.2	32	9.5	75
5.3	33		

TIP MOUNT

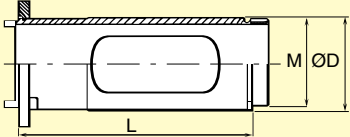

Model	Max stroke	Dimensions, mm			Ordering No.
		L	D	M	
LBL35	73	159	60	M56x1.5L	4140 0090 80
LBL45	110	215	80	M56x1.5L	4140 0092 80

DRILL GUIDE (Screw mount)

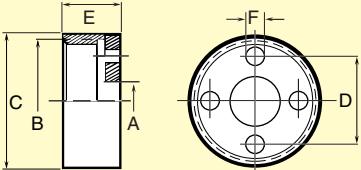

A ^a	B	C	D	E	F	G	H	I	Ordering No.
8, 10, 12,	M56x	60	39	25	6.2				4140 0044 08,
	1.5L	(2.36)	(1.54)	(0.98)	(0.24)				-10, -12

^a Dimensions mentioned under A refer to the outside diameter for drill guide bushings.

DRILL GUIDE (Bayonet mount)

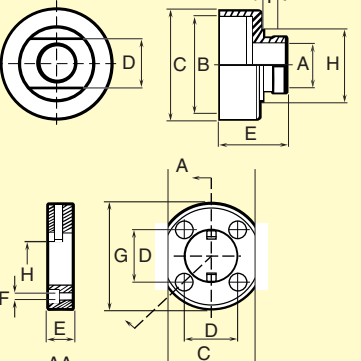

A ^a	B	C	D	E	F	G	H	I	Ordering No.
4	M56x	60	30	37			40h8	6.2	4140 0058 04,
18	1.5L	(2.36)	(1.18)	(1.46)			(1.57)	(0.31)	4140 0058 18
		56	36	15	6.5	67	40F8		4140 0059 80
		(2.20)	(1.50)	(0.59)	(0.26)	(2.64)	(1.57)		

^a Dimensions mentioned under A refer to the outside diameter for drill guide bushings.

AUTOMATIC DRILLING AND TAPPING UNITS

Dimension sketches

MOUNTINGS

Ref. No.	Designation	Ordering No.	
		LBL25, LBL35	LBL45
1	Base plate	4140 0077 80	4140 0081 80
2	Base plate	4140 0080 80	4140 0084 80
3	Column mount	4140 0050 00	
4	Side mount	4140 0047 80	4140 0018 80
5	Crossmount	4140 0048 80	4140 0029 80
6	Column socket		
	500 mm long	4140 0051 01	
	250 mm long	4140 0051 02	
	600 mm long		4140 0019 02
	300 mm long		4140 0019 01
7	Column		
	500 mm long	4140 0052 01	
	600 mm long		4140 0020 02
	300 mm long		4140 0020 01
8	Locking bar	4140 0078 00 ^a	4140 0082 00 ^a
9	Locking bar	4140 0079 00 ^a	4140 0083 00 ^a

^a Two per unit.

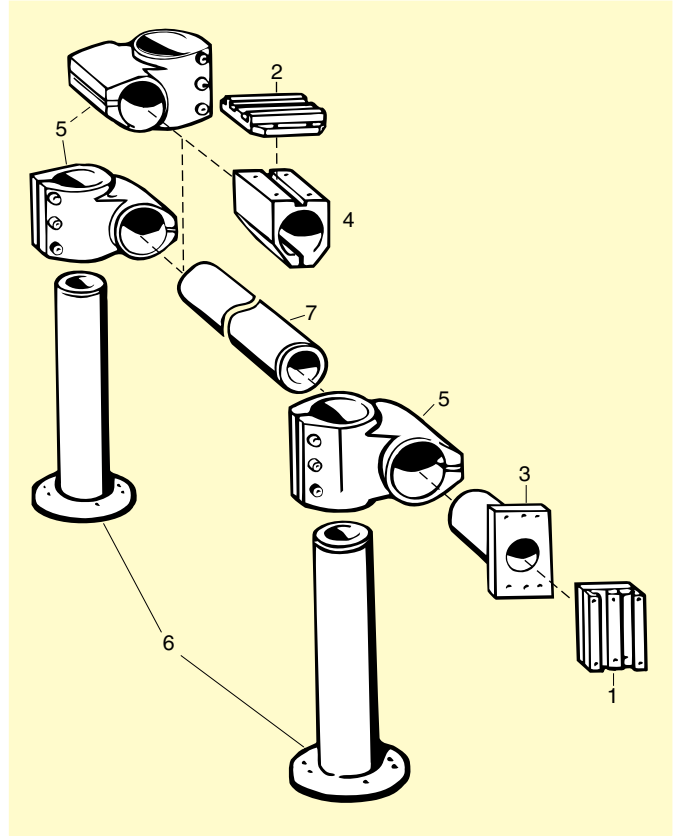

DIMENSION SKETCH – LBL25

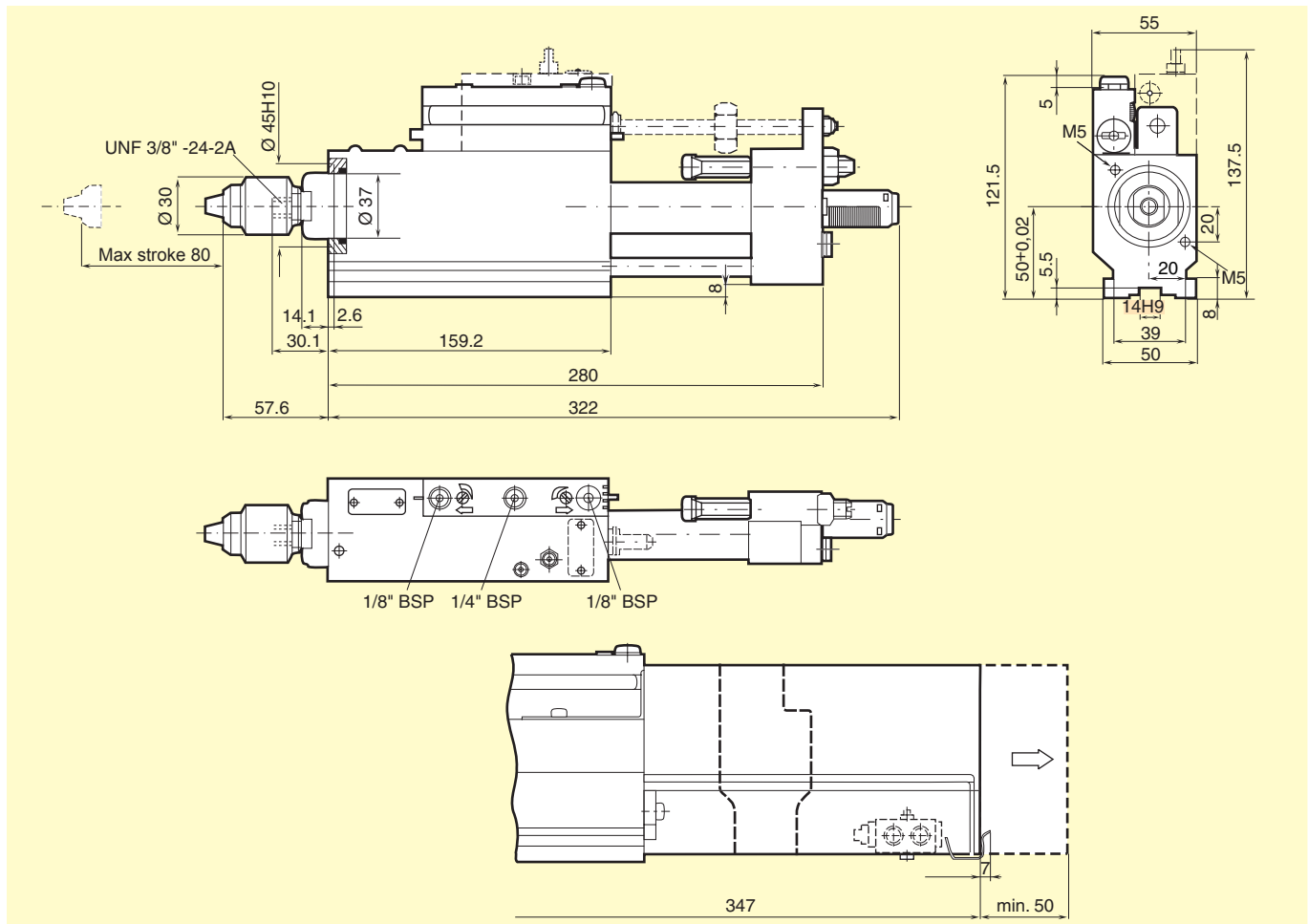

AUTOMATIC DRILLING AND TAPPING UNITS

Dimension sketches

DIMENSION SKETCH – LBL35

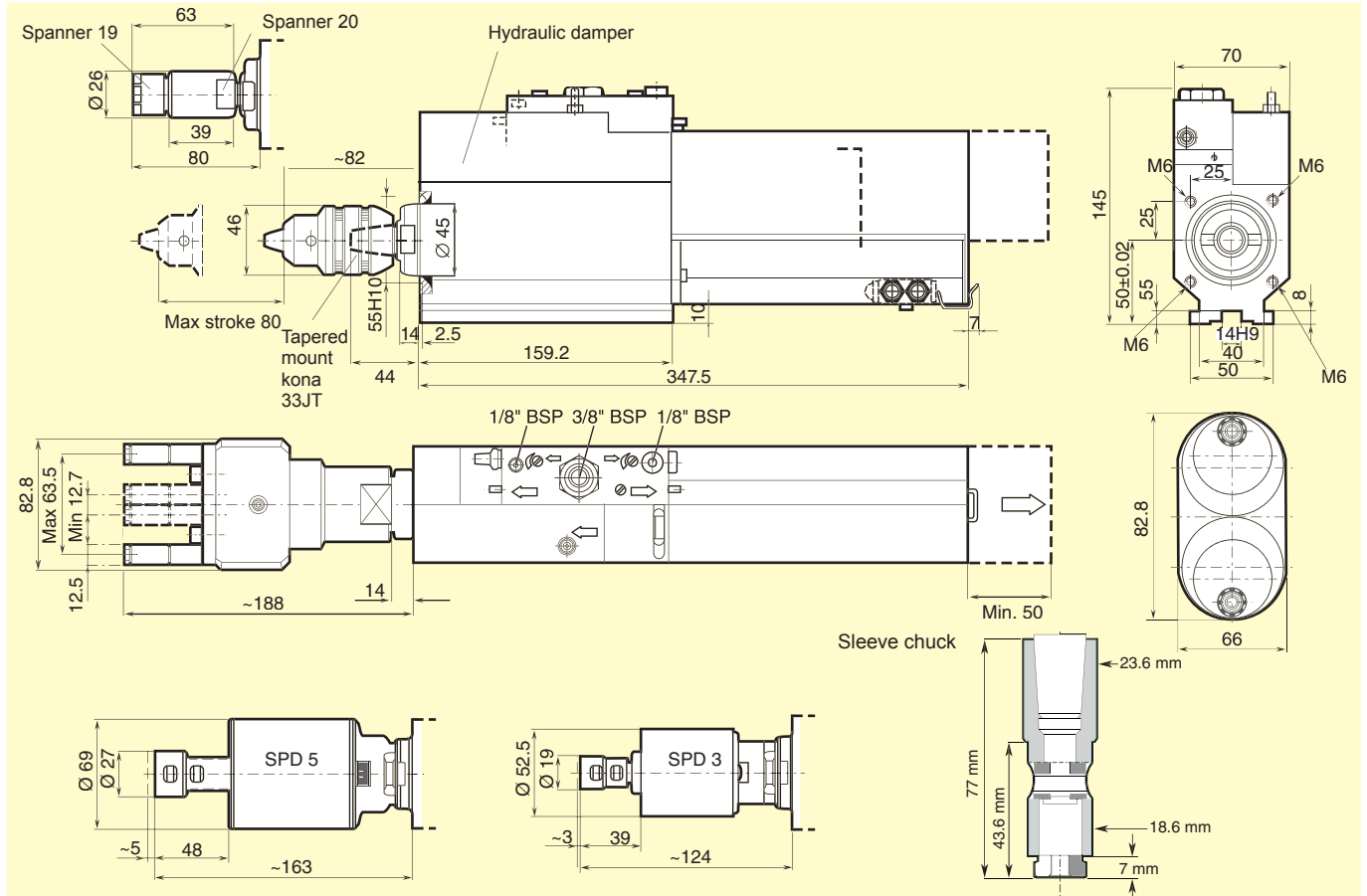

DIMENSION SKETCH – Mountings for LBL25E and -35E

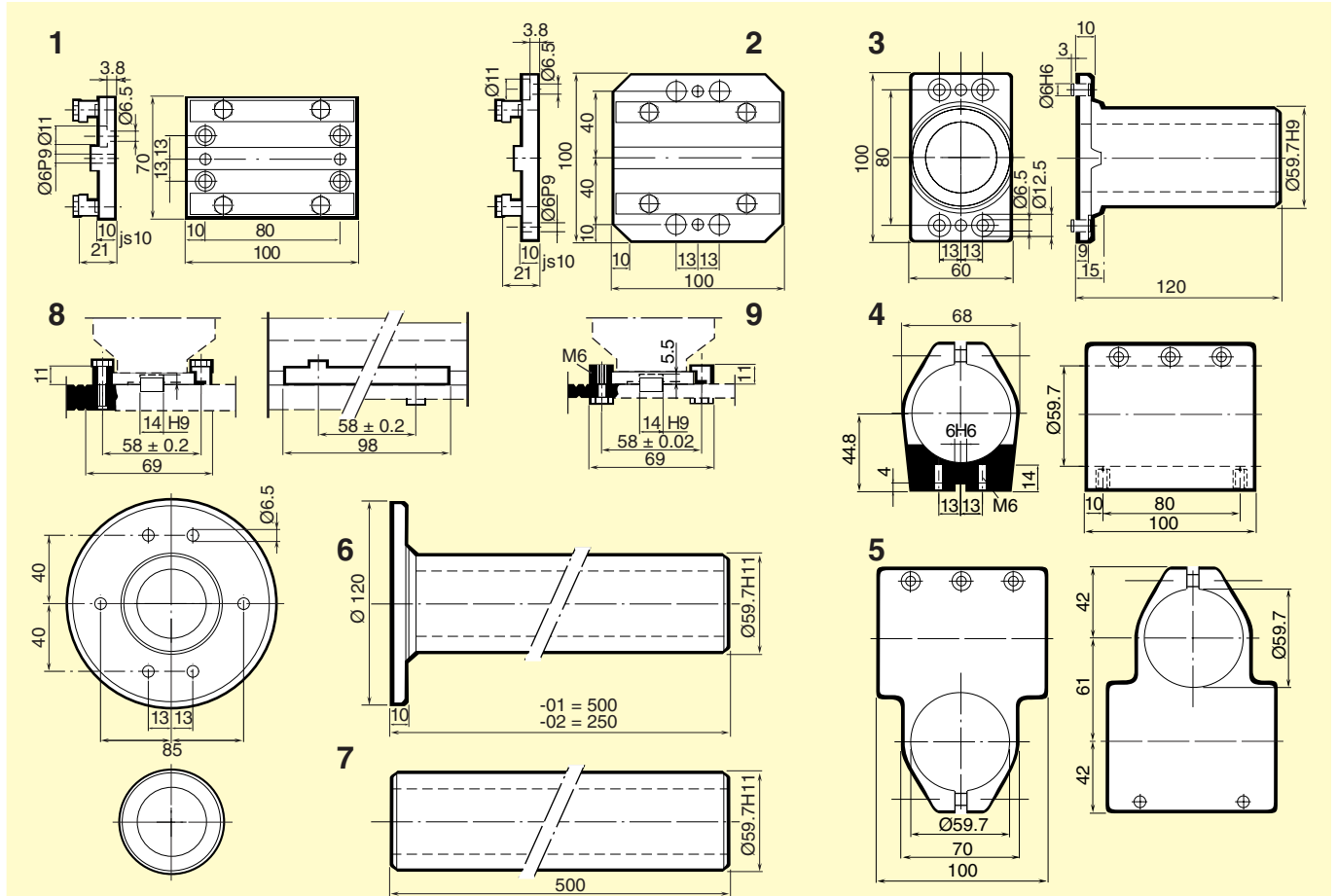

AUTOMATIC DRILLING AND TAPPING UNITS

Dimension sketches

DIMENSION SKETCH – LBL45

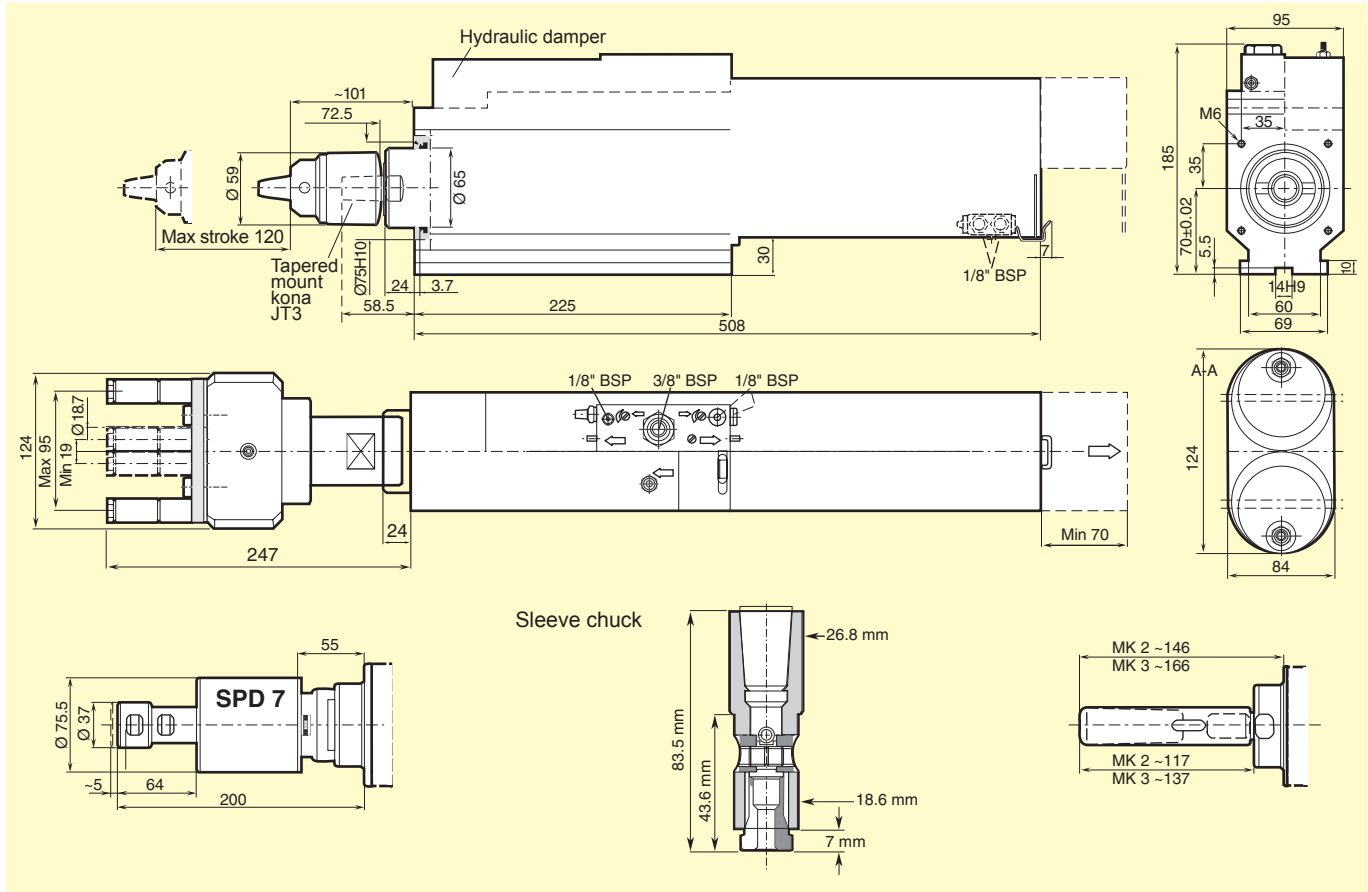

DIMENSION SKETCH – Mountings for LBL45E

