

## Control head for hygienic process valves

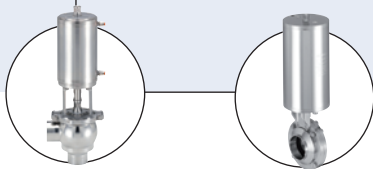

Type 8681 can be combined with...



Single seat valve  
Double seat valve

Butterfly valve  
Ball valve

- Universal attachment for hygienic process valves
- Contactless position measurement system with 3 switching points (Teach-In function)
- Coloured status display
- Manual override operative with closed housing
- Communication AS-Interface, DeviceNet (option)

The type 8681 control head is optimised for decentralised automation of hygienic process valves. Thanks to its universal adapter it can be combined with all normal commercial butterfly valves, ball valves, single and double seated valves. With a decentralised automation concept, the control head takes over all pneumatic actuation, feedback and diagnostic functions up to and including field bus communication. The housing is easy to clean and features proven electrical IP protection and chemically resistant materials for use in hygienic processing in food, beverage and pharmaceutical industries. Depending on the process valve type, up to 3 pneumatic actuator chambers can be controlled independently from each other. The switching speeds of both movement directions can be set separately. A built-in check valve prevents incorrect switching of process valve actuator chambers which could result from back-pressure.

The process valve switching positions are detected by an inductive, analogue position sensor and reported to the PLC system. Up to 3 switching points can be adjusted automatically by a Teach-In function. Additionally a fourth switching position can be read in and fed back via an external inductive proximity switch. The coloured status display signals the particular process valve switching position or indicates a diagnostic function such as maintenance required status or fault conditions.

The pilot valves are equipped with a manual override. If the device housing is closed, the patented magnetically encoded manual override tool can be used to open the process valve from the exterior. Bus communication is available with AS-interface or DeviceNet.

Technical data	
<b>Material</b>	PA, PPO, VA PC CR, EPDM
<ul style="list-style-type: none"> <li>▪ Body</li> <li>▪ Cover</li> <li>▪ Seal</li> </ul>	
<ul style="list-style-type: none"> <li>▪ Control medium</li> <li>▪ Dust concentration</li> <li>▪ Particle density</li> <li>▪ Pressure condensation point</li> <li>▪ Oil concentration</li> </ul>	neutral gases, air DIN ISO 8573-1 (filter 5 µm recommended) class 5 (<40 µm particle size) class 5 (<10 mg/m <sup>3</sup> ) class 3 (<-20°C) class 5 (<25 mg/m <sup>3</sup> )
<b>Supply pressure</b>	2,5 ... 8 bar
<b>Air capacity solenoid valve<sup>1)</sup></b> (supply and exhaust air per solenoid valve adjustable)	110lN/min - for pressurization and exhaust, lifting device 110lN/min - delivery condition 200lN/min - max. typical flow rate (throttle)
<b>Pilot air ports</b>	G 1/4 G 1/8
<ul style="list-style-type: none"> <li>▪ Air inlet and outlet</li> <li>▪ Service ports</li> </ul>	
<b>Position sensor</b>	non-contact Position Sensor , 3 self-regulated switching points PNP (Teach-In-function) closer (normally open), PNP-output short-circuit proof , with clocking short-circuit protection max. 100 mA per feedback signal
<ul style="list-style-type: none"> <li>▪ Outlet current</li> <li>▪ Stroke range</li> <li>▪ Resolution</li> <li>▪ Total error</li> </ul>	0 to 80 mm ≤ 0,1 mm ± 0,5 mm - when using a target for the dimensional drawing, material 1.4021 and a piston rod (Ø 22 mm, material 1.4301) (error refers to the reproducibility of a teach-position)
<b>Ambient temperature</b>	-10 to +55°C +5 to +55°C (ATEX II 3G Ex nA IIC T4; ATEX II 3G Ex tD A22 T135°C)
<b>Installation</b>	As required, preferably with actuator in upright position

<sup>1)</sup> QNn-value acc. to the definition with decrease in pressure from 7 to 6 bar absolute with 20°C.

Technical data, continued

Type of protection	IP 65/67 acc. to EN 60529
Protection class	3 (AS-Interface, 24 VDC, DeviceNet); 1 (120 VAC) acc. to DIN EN 61140
Fieldbus communication	AS-Interface, DeviceNet
EG-Conformity	EMV2004/108/EG; ATEX 94/9/EG
Ignition protection	ATEX II 3G Ex nA IIC T4 ATEX II 3G Ex tD A22 T135°C

Without fieldbus communication; 24VDC	
Operating voltages	12 to 28 VDC
Residual ripple with DC	max. 10 %
Power consumption	< 5 W (acc. to version and operating status see instruction manual)
Valve control inputs (Y1 - Y3) <ul style="list-style-type: none"> <li>Signal level - active</li> <li>Signal level - inactive</li> <li>Impedance</li> </ul>	U > 10 V, max. 24 V DC + 10% U < 5 V U > 30 kOhm
Outputs / binary feedback signals <ul style="list-style-type: none"> <li>Design</li> <li>Switchable output current</li> <li>Output voltage -active</li> <li>Output voltage -inactive</li> </ul>	S1 out - S4 out Normally open contact, PNP output short-circuit proof with self-clocking short circuit protection max. 100 mA per feedback signal ≥ (operating voltage - 2 V) max. 1 V in unloaded state
Input / proximity switches (external initiator: S4 in) <ul style="list-style-type: none"> <li>Power supply</li> <li>Current carrying capacity, sensor power supply</li> <li>Design</li> <li>Input current 1 signal</li> <li>Input voltage 1 signal</li> <li>Input current 0 signal</li> <li>Input voltage 0 signal</li> </ul>	Voltage present at control head - 10 % max. 90 mA short-circuit protection DC 2- and 3-conductor, NO or NC (factory setting NO), PNP output $I_{\text{Sensor}} > 6.5 \text{ mA}$ , limited internally to 10 mA $U_{\text{Sensor}} > 10 \text{ V}$ $I_{\text{Sensor}} < 4 \text{ mA}$ $U_{\text{Sensor}} < 5 \text{ V}$
Electrical connection <ul style="list-style-type: none"> <li>Multipole</li> <li>Cable gland</li> </ul>	M12 12-pin with cable 8 cm, 1 x M16 x 1.5 cable glands for external initiator (clamping range 3 ... 6 mm) M16 x 1.5 (cable-Ø 5 ... 10 mm, screw terminals 0.14 ... 1.5 mm2), 1 x M16 x 1.5 cable glands for external initiator (clamping range 3 ... 6 mm)

Without fieldbus communication; 120VAC	
Central power supply	110...130 V AC, 50/60 Hz
Power Consumption (stand by current)	10 mA at 120 V AC
Valve control inputs (Y1 - Y3) <ul style="list-style-type: none"> <li>Signal level - active</li> <li>Signal level - inactive</li> <li>Impedance</li> </ul>	U > 60 V AC U < 20 V AC > 40 kOhm
Outputs / binary feedback signals <ul style="list-style-type: none"> <li>Design</li> <li>Switchable output current</li> <li>Output voltage -active</li> <li>Output voltage -inactive</li> </ul>	S1 out - S3 out Normally open contact, L switching, short-circuit protection via automatically resetting fuse max. 50 mA per feedback signal ≥ (operating voltage - 2 V) max. 1 V in unloaded state
Input / proximity switches (external initiator: S4 in) <ul style="list-style-type: none"> <li>Power supply</li> <li>Current carrying capacity, sensor power supply</li> <li>Design</li> <li>Input current 1 signal</li> </ul>	Voltage present at control head - $U_{\text{Nominal}} = 120 \text{ V AC, 50/60 Hz}$ max. 0.7 DC 2- and 3-conductor, NO contact, L-switching $I_{\text{Sensor}} < 2 \text{ mA}$
Electrical connection <ul style="list-style-type: none"> <li>Cable gland</li> </ul>	M16 x 1.5 (cable-Ø 5 ... 10 mm, screw terminals 0.14 ... 1.5 mm2), 1 x M16 x 1.5 cable glands for external initiator (clamping range 3 ... 6 mm)

With fieldbus communication; AS-Interface	
<b>Profil</b>	S-7.A.E (A/B slave max. 62 slaves/master) S-7.F.F (max. 31 slaves/master)
<b>Operating voltages</b> ▪ above bus line ▪ from bus signal seperated	as Specification reversible (Jumper)
<b>Power consumption equipment without external power supply</b> <b>Max. Current consumption</b> ▪ Current consumption in normal operation (acc. to reduction of electric current; valve + 1 end positon achieved) <b>Power consumption equipment with external power supply</b> ▪ The power supply unit must include a secure disconnect in accordance with IEC 364-4-41. It must conform to the SELV standard. The ground potential may not have an earth connection.	240 mA (incl. external initiator with 90 mA) ≤ 150 mA 3 valves activated, 1 position feedback with LED display, no external initiator  19,2 V DC up to 31.6 V DC ≤ 100 mA 24 V DC ≤ 150 mA type.
<b>Output</b> ▪ Contact rating ▪ Watch-dog function	0,8 W with AS-Interface, per Solenoid Valve (0,9 W Switch-on power) integrated
<b>Input / proximity switches (externer Initiator: S4 in)</b> ▪ Power supply ▪ Current carrying capacity, sensor power supply ▪ Design ▪ Input current 1 signal ▪ Input voltage 1 signal ▪ Input current 0 signal ▪ Input voltage 0 signal	AS interface voltage present at control head - 10 % max. 30 mA short-circuit protection DC 2- and 3-conductor, NO or NC (factory setting NO), PNP output $I_{Sensor} > 6,5 \text{ mA}$ , limited internally to 10 mA $U_{Sensor} > 10 \text{ V}$ $I_{Sensor} < 4 \text{ mA}$ $U_{Sensor} < 5 \text{ V}$
<b>Electrical connection</b> (ASI flat cable clip at cable 80cm as standard)	M12 4-pin at cable 8 cm (acc. 0.3 m cable length acc. to AS-Interface Specification) 1 x M 16 x 1.5 cable glands for external initiator clamping range 3 ... 6 mm. M12 4-pin at cable 80 cm (acc. 1.0 m cable length acc. to AS-Interface Specification) 1 x M 16 x 1.5 cable glands for external initiator clamping range 3 ... 6 mm.

With fieldbus communication; DeviceNet	
<b>Electrical power supply</b>	11 to 24V DC (acc. to specification)
<b>Max. power consumption</b>	200 mA at 24 V DC
<b>Input / proximity switches (externer Initiator: S4 in)</b> ▪ Power supply ▪ Current carrying capacity, sensor power supply ▪ Design ▪ Input current 1 signal ▪ Input voltage 1 signal ▪ Input current 0 signal ▪ Input voltage 0 signal	via DeviceNet power supply - 10 % max. 30 mA DC 2- and 3-conductor, NO contact, PNP output $I_{Sensor} > 6,5 \text{ mA}$ , limited internally to 10 mA $U_{Sensor} > 10 \text{ V}$ $I_{Sensor} < 4 \text{ mA}$ $U_{Sensor} < 5 \text{ V}$
<b>Outputs (from master perspective) / solenoid valves</b> ▪ Max. switching capacity ▪ Typ. continuous output ▪ Output reduction ▪ Pull-in current ▪ Holding current ▪ Operating mode ▪ Valve type	1.0 W 0.8 W integrated via DeviceNet interface electronics 120 mA typ. at 24 V DC (3 valves) 100 mA typ. at 24 V DC (3 valves) Long-term operation (100% operation) 6524
<b>Electrical connection</b> ▪ Multipole	M12 5-pin with cable 80 cm, 1 x M16 x 1.5 cable glands for external initiator (clamping range 3 ... 6 mm)

## Technical data, continued

### Bit configuration

Databit	D3	D2	D1	D0
Input	external initiator S4	position 3	position 2	position 1
Output	not configured	solenoid valve 3	solenoid valve 2	solenoid valve 1
Parameterbit	D3	D2	D1	D0
Output	not configured	not configured	not configured	not configured

### Programming data

Databit	Programming data with 62 Slaves AS-Interface - apparat for A/B-Slave- addressing (standard device)	Programming data with 31 Slaves AS-Interface (optional)
E/A - configuration	7 hex (4 Inputs / 4 Outputs) see bit configuration chart	7 hex (4 Inputs / 4 Outputs) see bit configuration chart
ID-code	A hex	F hex
combinative ID-code 1	7 hex	(F hex)
combinative ID-code 2	E hex	(F hex)
profil	S-7.A.E	S-7.F.F

## Flange for process valve

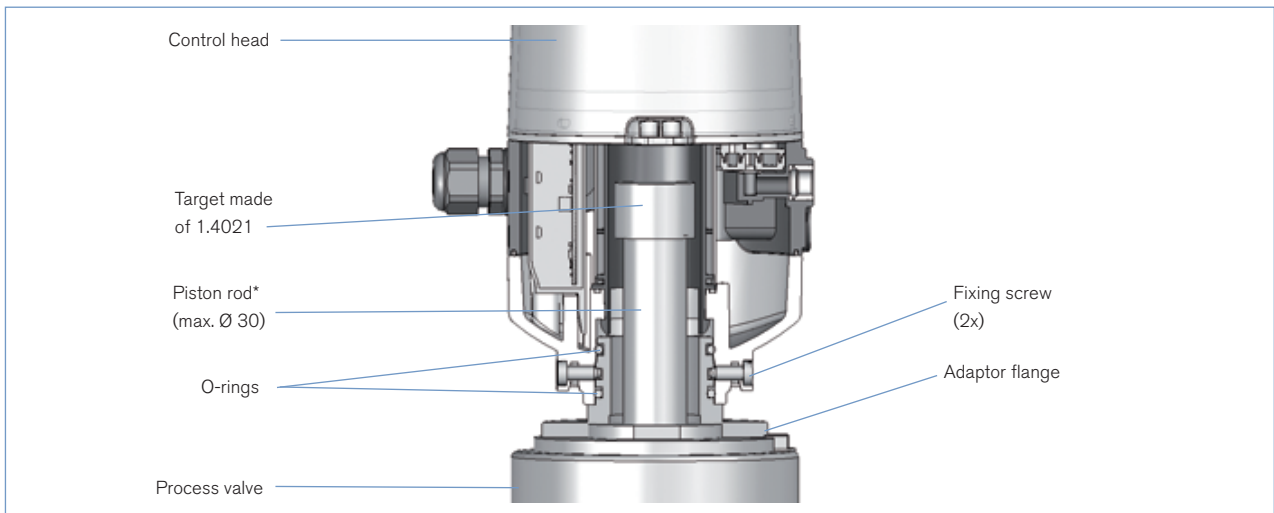

\*Target and piston should not be made of ferromagnetic or material with high electrical conductivity (e.g. copper, aluminium). Stainless steels such as 1.4404 are suitable.

## Materials

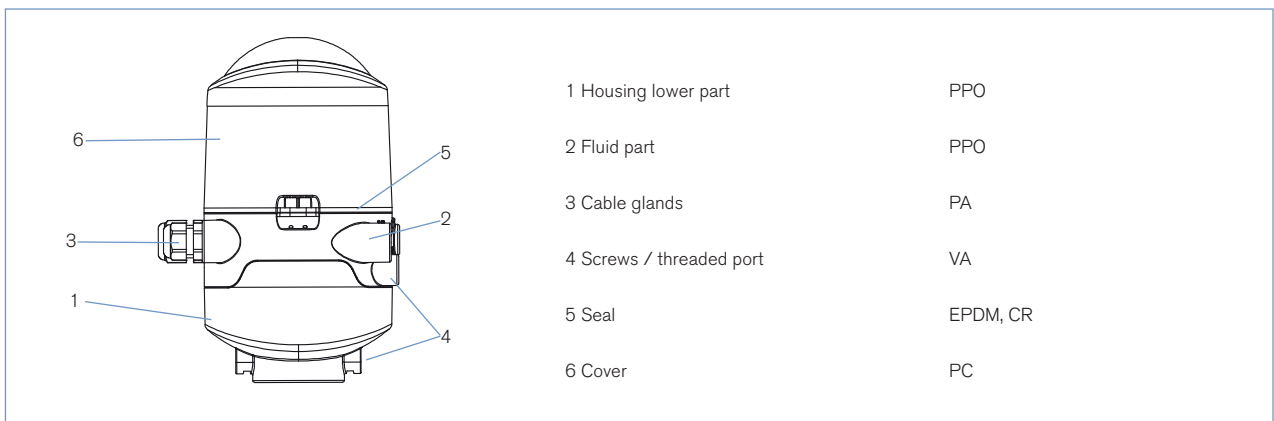

Connections, continued

Without fieldbus communication 24VDC

Cable glands

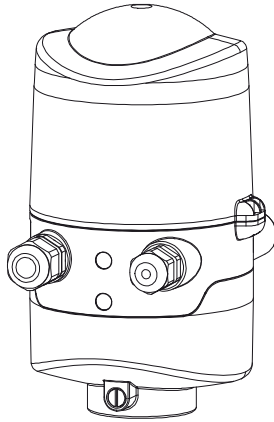

Connection left: Voltage, signals  
Connection right: external initiator

Cable glands with multipol connection

Version with 12 pin plug (24 V)<sup>1)</sup>

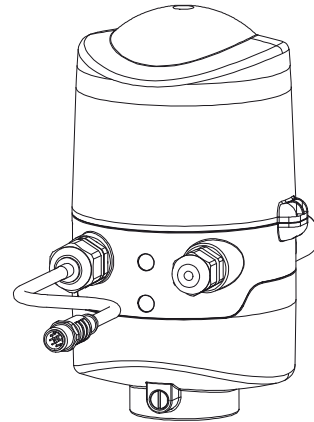

Connection left: Voltage, signals  
Connection right: external initiator

<sup>1)</sup> M12 plug acc. IEC 61076-2-101, 12 pin at cable 8 cm

Multipol connection M12, 12-pin

In- and Outputsignal for superordinated control (SPS):

12-pin terminal M12 x 0,75 - male (acc. IEC 61076-2-101)

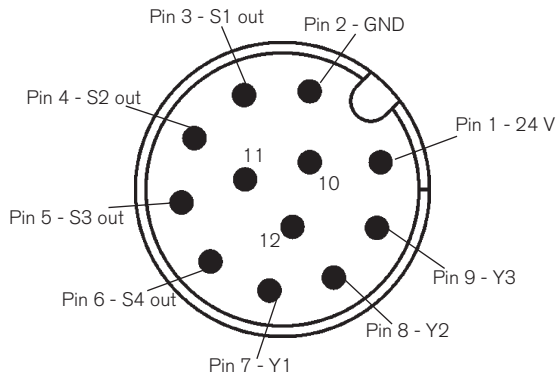

Pin	Description	Configuration
1	24 V	power supply 24 V
2	GND	GND
3	S1 out	Output position S1
4	S2 out	Output position S2
5	S3 out	Output position S3 <sup>1)</sup>
6	S4 out	Output externer Initiator S4
7	Y1	Input Solenoid valve 1
8	Y2	Input Solenoid valve 2
9	Y3	Input Solenoid valve 3
10		not configured
11		not configured
12		not configured

<sup>1)</sup> in ordering option "analog", S3 out is a analog signal instead of a binary signal

Connections, continued

Without fieldbus communication 24VDC cable glands

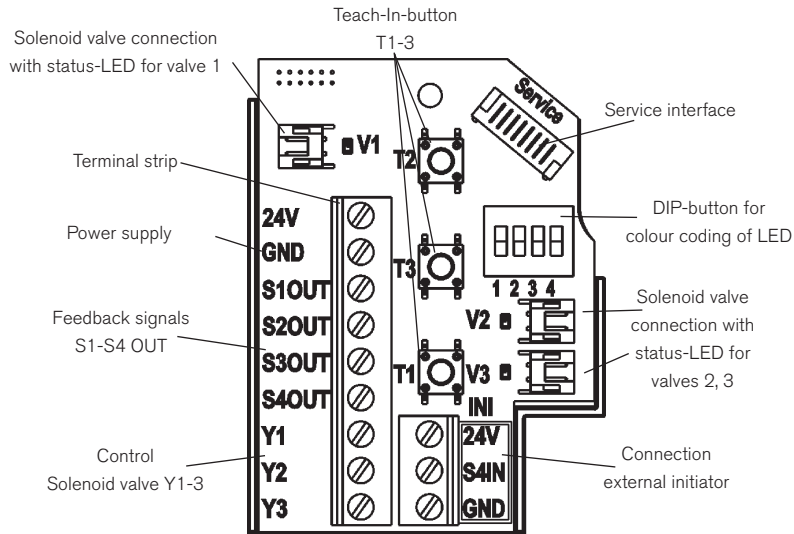

Description Terminal strip	Configuration
24 V	Power consumption 24 V
GND	GND
S1 OUT	Output position 1
S2 OUT	Output position 2
S3 OUT	Output position 3 <sup>1)</sup>
S4 OUT	Output external initiator
Y1	Input Solenoid valve 1
Y2	Input Solenoid valve 2
Y3	Input Solenoid valve 3

Description Terminal strip	Configuration
24 V	Power consumption 24 V for external initiator
S4 IN	Input external initiator
GND	GND external initiator

<sup>1)</sup> in ordering option "analog", S3 out is a analog signal instead of a binary signal

Without fieldbus communication 120VAC

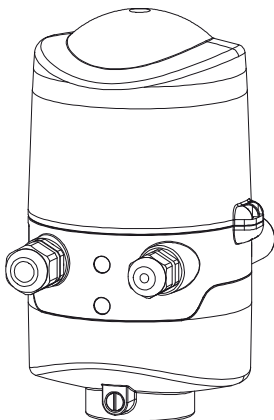

Connection left: voltage, signals  
Connection right: external initiator

Description Terminal Strip 1	Configuration	
PE	Protection Earth - protective conductor	
L	Power supply	live conductor
N	120 V AC	neutral conductor
S1 OUT	Output position 1	
S2 OUT	Output position 2	
S3 OUT	Output position 3	
S4 OUT	Output external initiator	
Y1	Input solenoid valve 1	
Y2	Input solenoid valve 2	
Y3	Input solenoid valve 3	
Description Terminal Strip 2	Configuration (external initiator)	
L	Power supply - live conductor	
S4 IN	Input external initiator	
N	Power supply - neutral conductor	

**Connections, continued**

**With fieldbus communication AS-Interface**

**with multipol connection<sup>1)</sup>**

(M12-plug acc. IEC 61076-2-101, 4-pin) at cable 8 cm

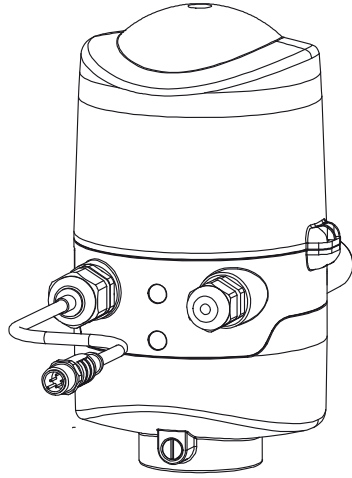

left: AS-Interface  
right: external initiator

**with multipol connection**

(M12-plug acc. IEC 61076-2-101, 4-pin) with mounted flat cable clip at cable 80 cm

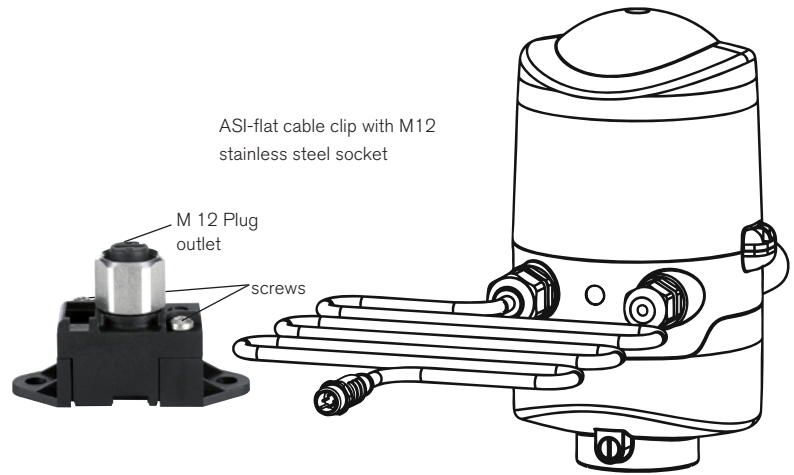

ASI-flat cable clip with M12 stainless steel socket

M 12 Plug outlet  
screws

left: AS-Interface  
right: external initiator

<sup>1)</sup>on request

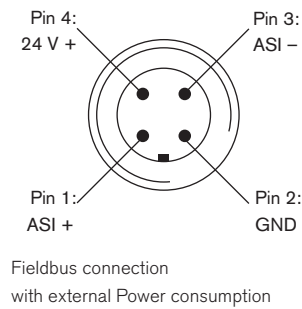
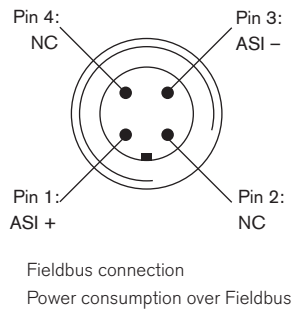

Pin	Configuration (Consumption over Fieldbus)	Configuration (external Power consumption)	Wire colour
1	AS-Interface - ASI +	AS-Interface - ASI +	brown
2	not configured	GND	white
3	AS-Interface - ASI -	AS-Interface - ASI -	blue
4	not configured	24 V +	black

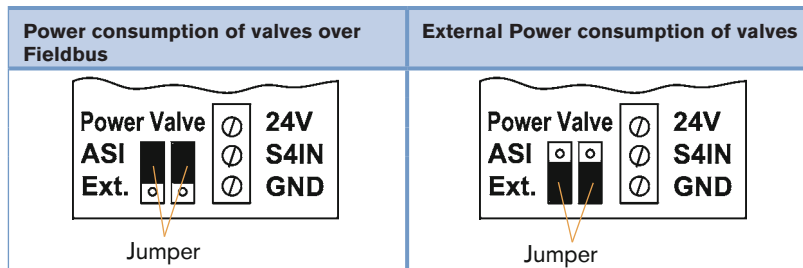

Connections, continued

With fieldbus communication DeviceNet

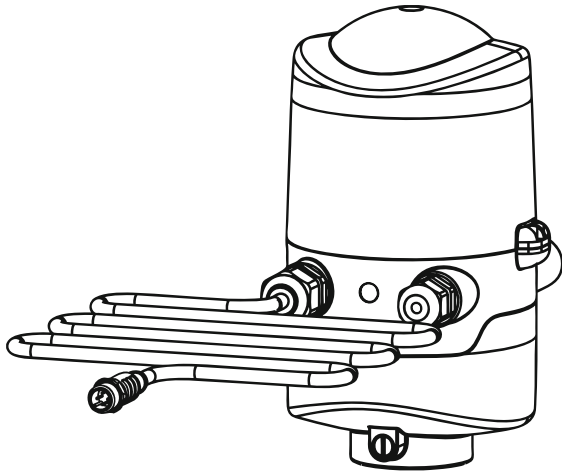

left connection: DeviceNet

right connection: external initiator

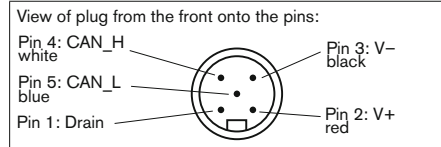

Pin	Signal	Wire colour
1	Drain	shield
2	V+	red
3	V-	black
4	CAN_H	white
5	CAN_L	blue

Pneumatic connection

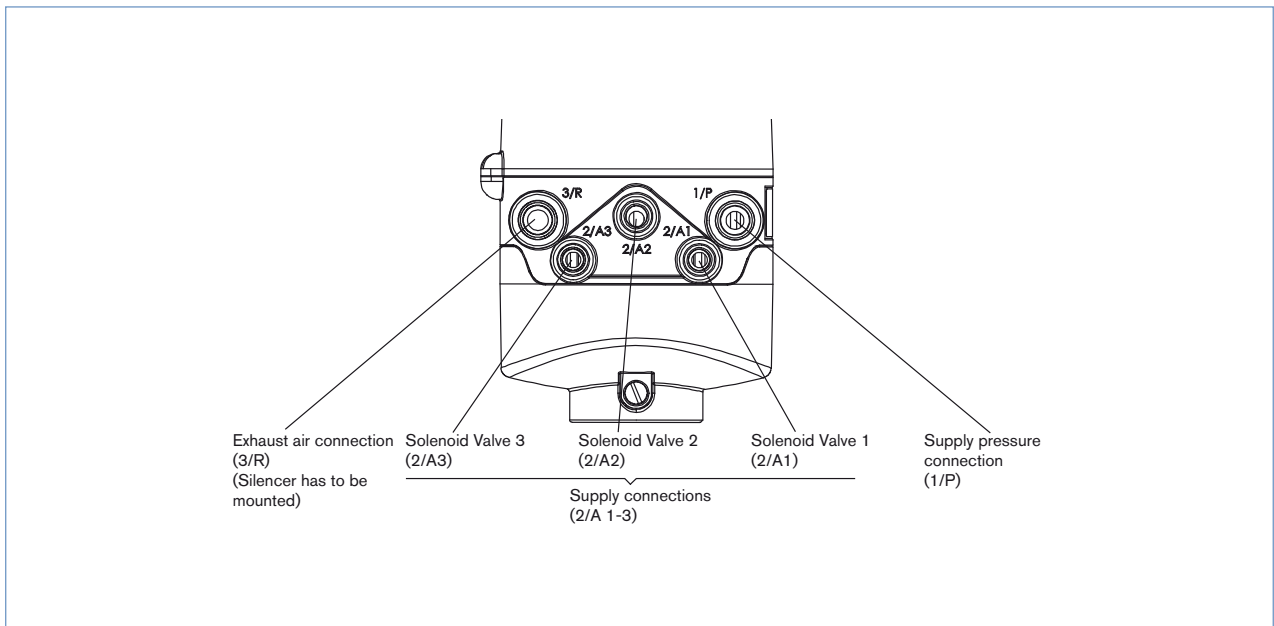



Magnetic manual override

Activation / De-Activation Solenoid valve 1 (process valve maintenance)

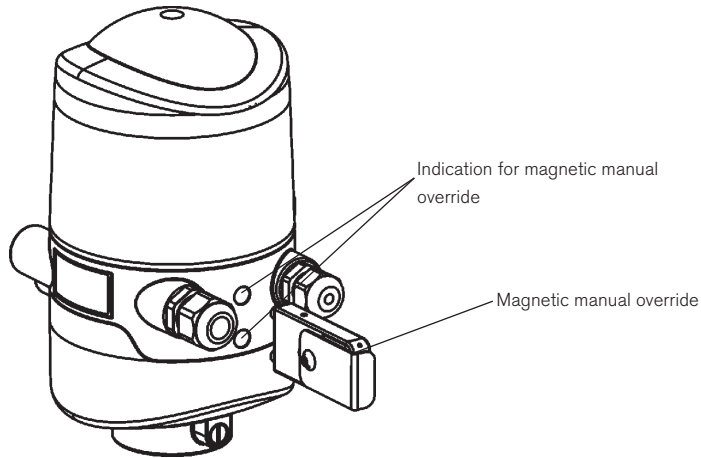

Version	Item no.
Magnetic manual override	196 490

Ordering chart Control head type 8681 (other versions on request )

Communication	Supply voltage	Connection	ATEX zone 2/22 cat. 3	Number of solenoid valves	Feedback	Item no.
without	12 ... 28 V DC	cable gland	without	0	3 int. + 1 ext.	196 410
			without	1	3 int. + 1 ext.	196 411
			without	2	3 int. + 1 ext.	196 412
			without	3	3 int. + 1 ext.	196 413
			with	1	3 int. + 1 ext.	196 415
	12 ... 28 V DC	M12, 12-pin, cable 8 cm	without	0	3 int. + 1 ext.	196 420
			without	1	3 int. + 1 ext.	196 421
			without	2	3 int. + 1 ext.	196 422
			without	3	3 int. + 1 ext.	196 423
			with	1	3 int. + 1 ext.	196 425
	120 V AC	cable gland	without	0	3 int. + 1 ext.	196 470
			without	1	3 int. + 1 ext.	196 471
			without	2	3 int. + 1 ext.	196 472
			without	3	3 int. + 1 ext.	196 473
			with	1	3 int. + 1 ext.	196 475
AS-Interface (62 slaves)	29,5 ... 31,6 V DC	version with ASI flat cable clip and cable 80 cm	without	0	3 int. + 1 ext.	196 430
			without	1	3 int. + 1 ext.	196 431
			without	2	3 int. + 1 ext.	196 432
			without	3	3 int. + 1 ext.	196 433
			with	1	3 int. + 1 ext.	196 435
DeviceNet	via Bus	M12, 5-pin, cable 80 cm	without	0	3 int. + 1 ext.	196 450
			without	1	3 int. + 1 ext.	196 451
			without	2	3 int. + 1 ext.	196 452
			without	3	3 int. + 1 ext.	196 453
			with	1	3 int. + 1 ext.	196 455

**i** Further versions on request

- >** **Additional**  
AS-Interface: connection M12 4-pin cable 8 cm  
Analog (4...20 mA) instead of binary Feedback signal only 24 V version  
AS-Interface (31 slaves)

Ordering chart for accessories

Version	Item no.
Silencer PE G 1/4 (spare part)	780 780
Blanking plugs PP G 1/8 (spare part)	770 901
Rotary push-in fitting, brass nickel-plated G 1/4 for Ø Tube 8/6	780 084
Rotary push-in fitting, brass nickel-plated G 1/8 for Ø Tube 6/4	780 082
Universal adaptor with O-ring	196 495
Position sensor target, stainless steel 1.4021	196 494
Magnetic tool for manual override	196 490
Cable 8 cm with 12 pin M12 plug for 24 V DC (spare part)	217 574
Cable 80 cm with 4 pin M12 plug for ASi (spare part)	217 572
Cable 8 cm with 4 pin M12 plug for ASi (spare part)	217 573
ASi- flat cable clip with stainless steel socket M12 (spare part)	799 646
Cable 80 cm with 5 pol M12 plug for DeviceNet (spare part)	218 187
USB adaptor kit PC communication	227 093
Bluetooth-adaptor kit smartphone-communication	196 497
Set of 20 lead seals; to impede toolless opening (spare part)	257 100

Dimensions [mm]

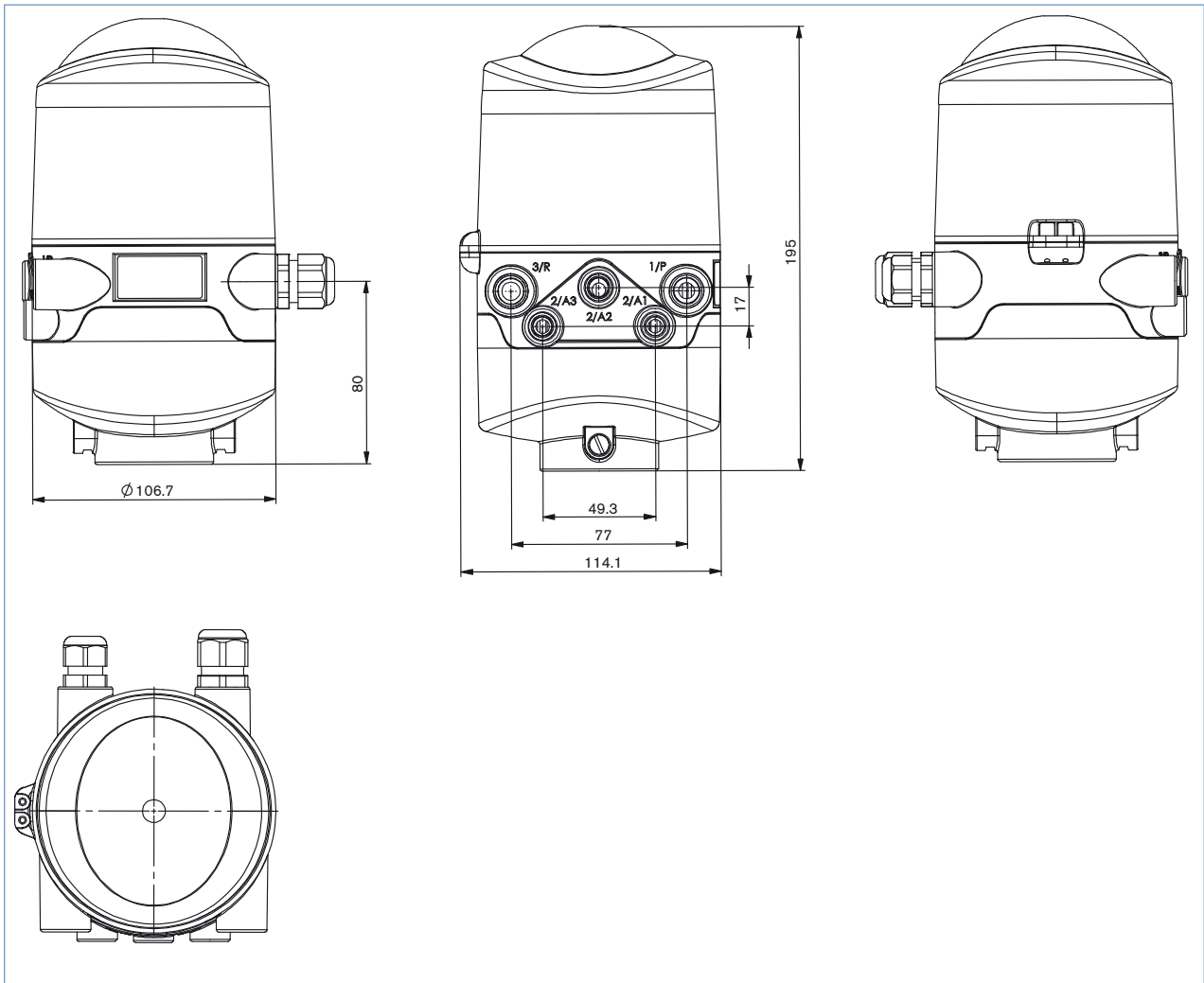

Dimensions [mm]

Feedback version (without pilot valves)

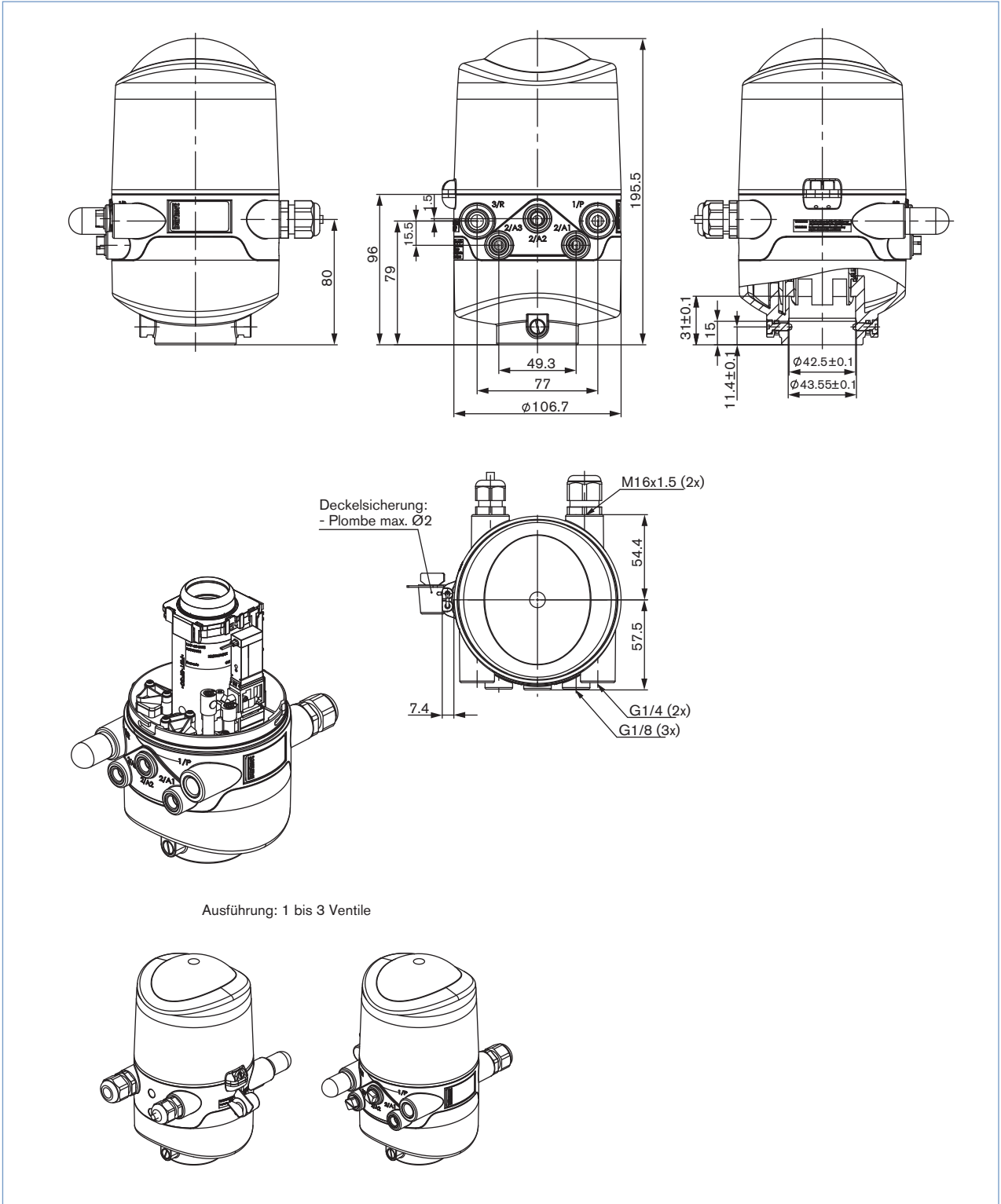

**Dimensions [mm], continued**

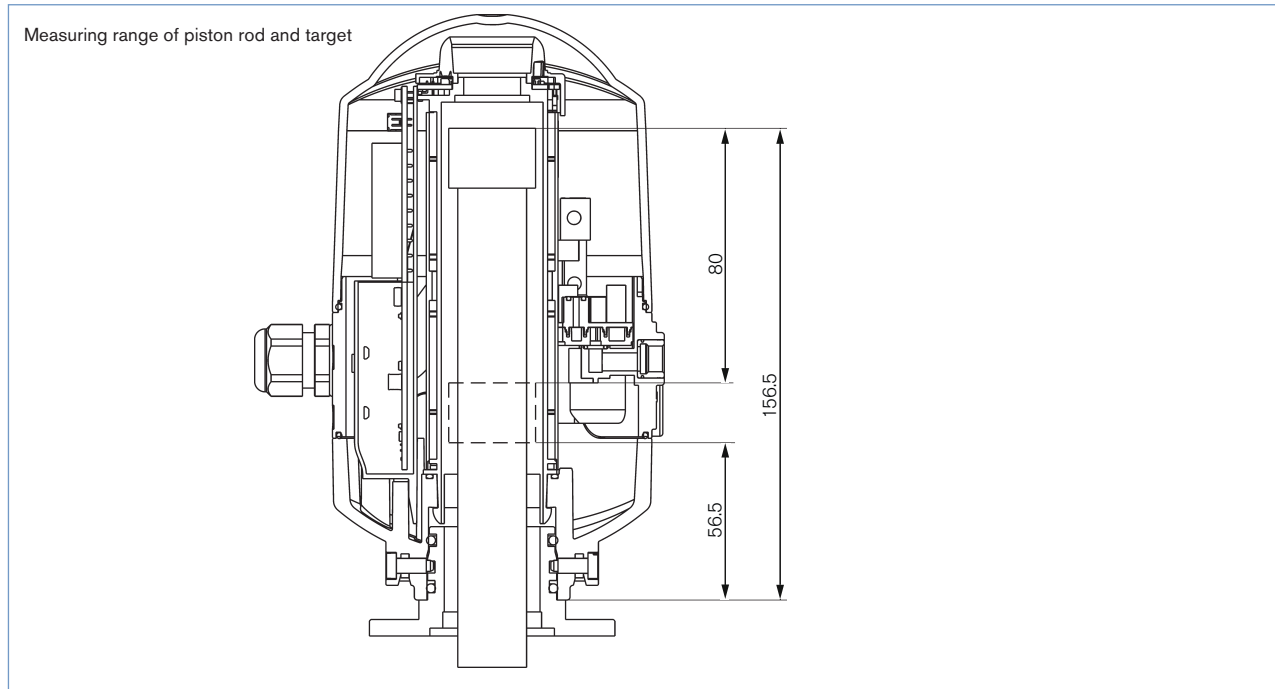

**Dimensions [mm], accessory**

196 495  
Universal VA-flange with O-ring

Manufacturing a customized flange adapter requires detailed drawing to ensure the control head functions and seals proper.

196 494  
Target for type 8681 (1.4021)

Version	Item no.
Universal VA flange with O-ring	196 495
Target for type 8681 (1.4021)	196 494

M 1 : 1

To find your nearest Bürkert facility, click on the orange box



[www.burkert.com](http://www.burkert.com)

In case of special application conditions,  
please consult for advice.

Subject to alteration.  
© Christian Bürkert GmbH & Co. KG

1309/2\_EU-en\_00895154