

## INSERTION Adapter/Fitting for analytical devices



Type S022 can be combined with...



**Type 8202**  
pH or O.R.P. meter



**Type 8222**  
Resistive conductivity meter

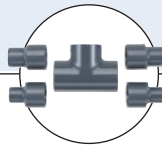

**Pipe and fitting**



**Saddle**

- Universal adapter/fitting for Type 8202 and 8222 measuring devices in pure, aggressive or polluted liquids
- Adaptation into standard piping systems or conversion of Bürkert S020 fittings to S022 fittings
- Pipe diameters from DN06 (with reduction) to DN110 (plastic) or bigger (stainless steel)

The adapter/fitting or measuring chamber is used to connect the compact analytical ELEMENT measuring device into piping systems.

Different versions of adapters/fittings are available:

Adapters:

- PVC-U adapter to stick into equal or reduced standard metric or ASTM Tee fitting
- PP adapter to weld into equal d32 standard metric Tee fitting
- Stainless steel adapter to weld
- PVC threaded adapter to screw on tank or pipe
- PVC, PP, stainless steel adapter for conversion of S020 Bürkert fitting into S022 fitting.

Fittings in PVC:

- metric or ASTM Tee fitting
  - True union connection
  - weld end connection
- saddle

General data	
<b>Pipe diameter</b>	DN06 (with reduction) to DN110 (plastic) or bigger (stainless steel)
<b>Process connection</b>	
Adapter	Solvent, fusion, welding, threaded and to connect with screws
Fitting	Metric or ASTM True union or weld ends; saddle
<b>Materials</b>	
Adapter	PVC, PP, stainless steel - delivered with 2 seals, 1 FKM and EPDM
Fitting	
Seal	FKM, EPDM
Body & adapter	PVC&PVC, PP&PVC
Medium data	
<b>Medium temperature</b>	See pressure-temperature chart on next page. Temperature limits may depend on inserted measuring device <sup>1)</sup> .
<b>Medium pressure (max.)</b>	PN10 (plastic) or PN16 (metal). Pressure limits may depend on inserted measuring device <sup>1)</sup> .
Environment	
<b>Ambient temperature</b>	Temperature limits may depend on inserted measuring device <sup>1)</sup> .

<sup>1)</sup>Please refer to appropriate instruction manual or data sheet for more details.

Standards, directives and approvals	
<b>Directive - Pressure</b>	Complying with article 3 of §3 from 97/23/CE directive.*

\* For the 97/23/CE pressure directive, the device can only be used under following conditions (dependent on max. pressure, pipe diameter and fluid).

Type of fluid	Conditions
Fluid group 1, §1.3.a	Only DN ≤ 25
Fluid group 2, §1.3.a	DN ≤ 32, or DN > 32 and PN*DN ≤ 1000
Fluid group 1, §1.3.b	DN ≤ 25, or DN > 25 and PN*DN ≤ 2000
Fluid group 2, §1.3.b	DN ≤ 125

Pressure / temperature chart

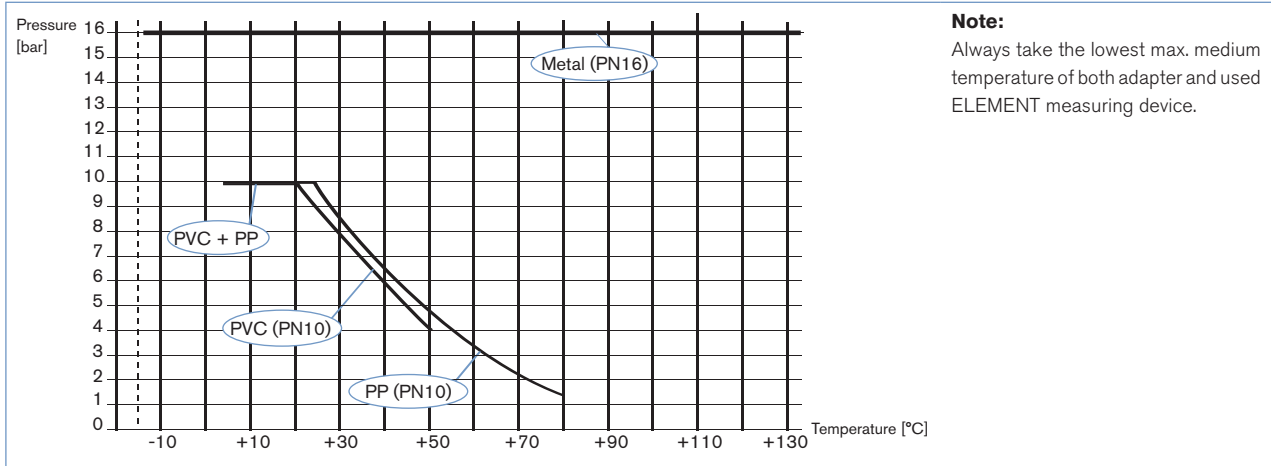

**Note:**  
Always take the lowest max. medium temperature of both adapter and used ELEMENT measuring device.

Adaptation overview

<b>Adapter/ fitting S022</b>					
	<b>PVC-U, PP metric or ASTM</b>	<b>Stainless steel</b>	<b>PVC-U, G or NPT 1 1/4" screw-on</b>	<b>PVC-U, PP, stainless steel for Bürkert fitting body</b>	
Piping systems					
Final products					
DN	32 to 110 (06 to 25 with reduction)	Respect recommendations of installation	Respect recommendations of installation	Respect recommendations of installation	32 to 50

## Installation and recommendations

For pH and ORP measurements, we recommend a "U"- form bypass installation to ensure that the electrode is maintained in a wet condition and enable the customer to calibrate the unit without stopping the whole process or to use the special designed measuring chamber.

The specially designed measuring chamber enables to install the measuring device in all pipe systems, either directly in the main stream or in a by-pass line. Additionally it enables to keep the electrode always wet and isolates it easily from the main stream for calibration purposes.

Pressure and temperature ratings must be respected according to the selected adapter material. Be sure that the sensor element is completely covered with liquid. Avoid dead legs which interfere the local fluid exchange.

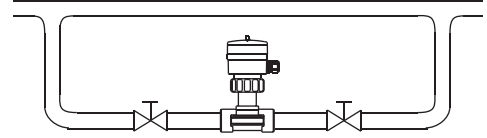

**When mounting the adapter into a T-fitting, a tank or directly into a pipe, please ensure that the minimum immersion depth of the electrode is respected (refer to the under drawing).**

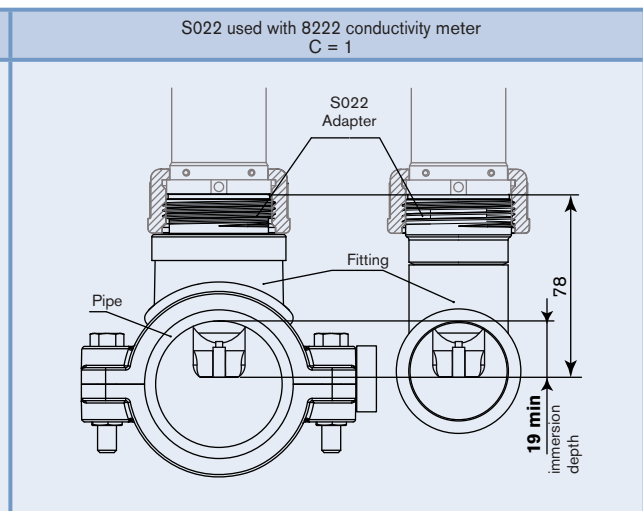
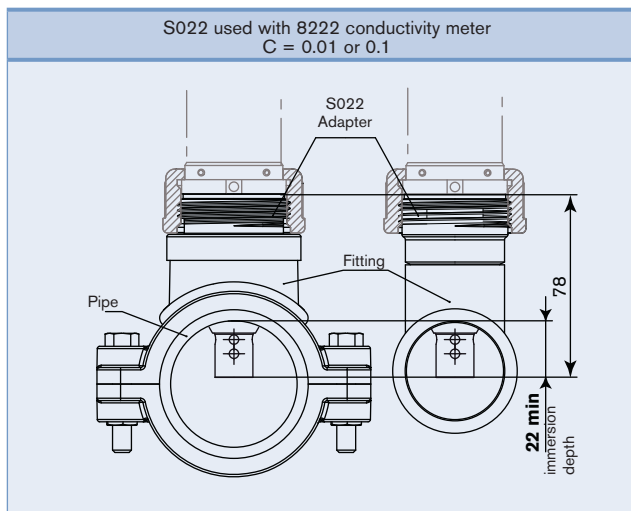
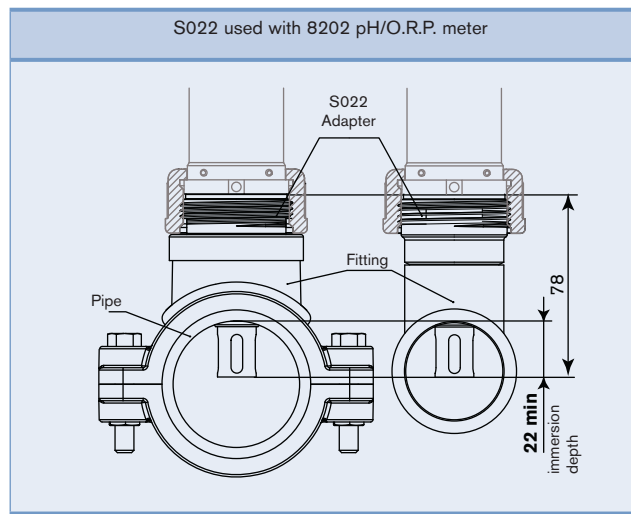

Dimensions for adapter/fitting S022

**INSERTION adapter for connection into T-fitting or pipe**

Note: T-fitting to use for mounting the S022, shown in the opposite drawing

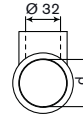

Metric solvent adapter  
PVC-U / FKM, EPDM

To stick on Tee fitting d32x32 or d40x32  
with solvent socket

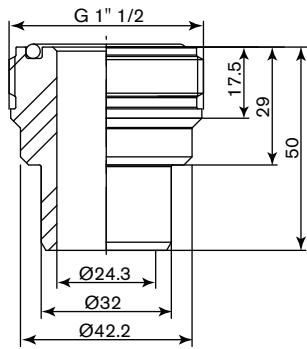

Metric solvent adapter  
PVC-U / FKM, EPDM

To stick on Tee fitting d50x32 to d50-110x32  
with solvent socket

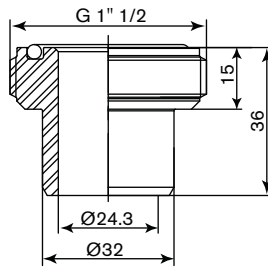

ASTM solvent adapter  
PVC-U / FKM, EPDM

To stick on Tee fitting 1"x1" to 3"x1"  
with solvent socket

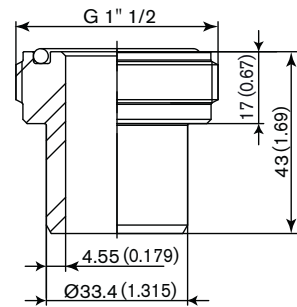

Metric fusion adapter  
PP / FKM, EPDM

To weld on Tee fitting d32x32  
with fusion socket

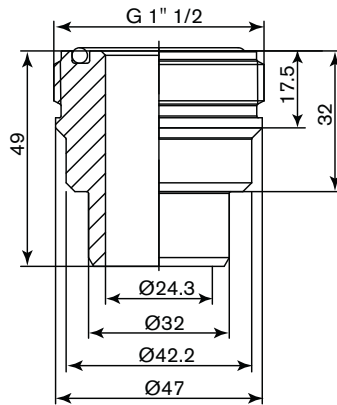

Metric welding  
Stainless steel / FKM, EPDM

To weld directly on pipe

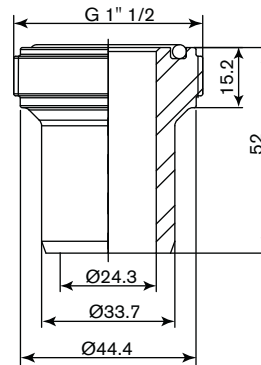

**INSERTION adapter for connection on tank or pipe**

G 1 1/4" screw-on adapter  
PVC-U / FKM, EPDM

to screw on tank or pipe

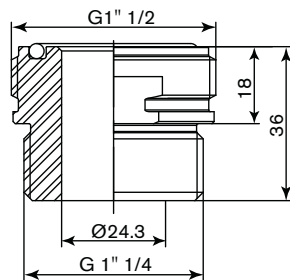

NPT 1 1/4" screw-on adapter  
PVC-U / FKM, EPDM

to screw on tank or pipe

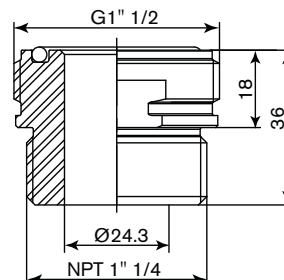

Dimensions for adapter/fitting S022

Fitting with metric solvent ends connection in PVC

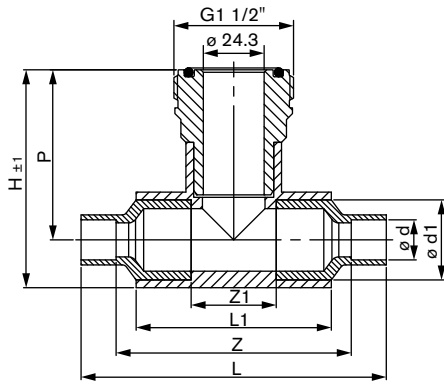

Fitting with ASTM solvent ends connection in PVC

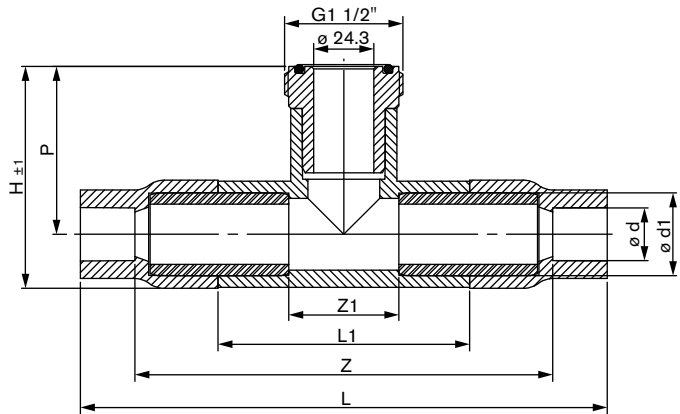

DN [mm]	P [mm]	H [mm]	Standard	L [mm]	L1 [mm]	Z [mm]	Z1 [mm]	Ø d [mm] [inch]	Ø d1 [mm] [inch]
10	68	87	Metric	122	78	94	34	16	32
	-	-	ASTM	-	-	-	-	-	-
15	68	87	Metric	126	78	94	34	20	32
	68	89	ASTM	213	102	168	44	1/2"	1"
20	68	87	Metric	132	78	94	34	25	32
	68	89	ASTM	224	102	175	44	3/4"	1"
25	68	87	Metric	-	78	-	34	-	32
	68	89	ASTM	-	102	-	44	-	1"
32	70	99	Metric	-	98	-	46	-	40
	71	98	ASTM	-	108	-	44	-	1 1/4"
40	65	96	Metric	-	118	-	56	-	50
	74	104	ASTM	-	114	-	44	-	1 1/2"
50	71	110	Metric	-	146	-	70	-	63
	77	114	ASTM	-	121	-	44	-	2"
65	78	124	Metric	-	168	-	80	-	75
	84	128	ASTM	-	133	-	44	-	2 1/2"
80	92	147	Metric	-	194	-	92	-	90
	87	140	ASTM	-	140	-	44	-	3"
100	104	171	Metric	-	234	-	112	-	110
	-	-	ASTM	-	-	-	-	-	-

Fitting with metric or ASTM true union connection with spigot and nut in PVC

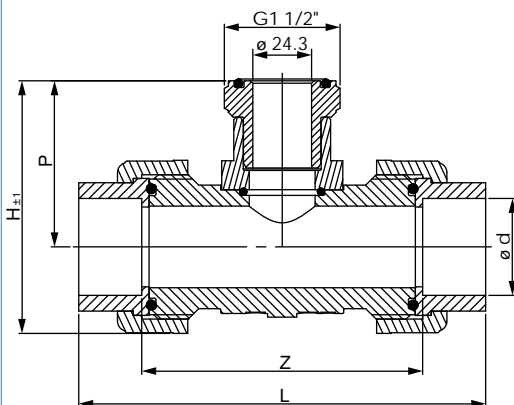

DN [mm]	P [mm]	H [mm]	Standard	L [mm]	Z [mm]	Ø d [mm] [inch]
15	69	104	Metric	148	116	20
			ASTM	162	116	1/2"
20	69	104	Metric	154	116	25
			ASTM	168	116	3/4"
25	69	104	Metric	160	116	32
			ASTM	174	116	1"
32	69	104	Metric	168	116	40
			ASTM	170	116	1 1/4"
40	72	113	Metric	188	126	50
			ASTM	190	126	1 1/2"
50	79	129	Metric	212	136	63
			ASTM	214	136	2"

Dimensions for adapter/fitting S022

**Fitting with saddle**

PP Body material  
& PVC adapter  
EPDM seal material

DN [mm]	M [mm]	P [mm]	H [mm]	A [mm]	Ø D [mm]
50	18	82	121	116	63
65	18	89	134	129	75
80	18	96	148	144	90
100	18	107	170	166	110
110	18	113	184	181	125

**Adapter to convert S020 T-fitting to S022**

Adapter  
PVC-U or PP/ FKM, EPDM  
For Bürkert fitting body - DN32 or bigger

Adapter  
Stainless steel / FKM, EPDM  
For Bürkert fitting body - DN32 or bigger

**Measuring chamber**





Stainless steel  
316L - 1.4404

Ordering chart for adapter/fitting S022

	Description	Materials Body / Seal <sup>1)</sup>	Type of installation or DN	Item no.		
<b>Insertion adapter for connection into T-fitting or pipe</b>						
	Metric solvent adapter with G 1 1/2" external threaded for ELEMENT measuring device connection	PVC-U / FKM, EPDM	To stick on Tee fitting d32x32 or d40x32 with solvent socket	560 705		
	Metric solvent adapter with G 1 1/2" external threaded for ELEMENT measuring device connection	PVC-U / FKM, EPDM	To stick on Tee fitting d50x32 to d50-110x32 with solvent socket	560 706		
	ASTM solvent adapter with G 1 1/2" external threaded for ELEMENT measuring device connection	PVC-U / FKM, EPDM	To stick on Tee fitting 1"x1" to 3"x1" with solvent socket	561 227		
	Metric fusion adapter with G 1 1/2" external threaded for ELEMENT measuring device connection	PP / FKM, EPDM	To weld on Tee fitting d32x32 with fusion socket	561 229		
	Metric welding adapter Ø 33.7 with G 1 1/2" external threaded for ELEMENT measuring device connection	Stainless steel / FKM, EPDM	To weld directly on pipe	561 232		
<b>Insertion adapter for connection into T-fitting or pipe</b>						
	G 1 1/4" screw-on adapter with G 1 1/2" external threaded for ELEMENT measuring device connection	PVC-U / FKM, EPDM	To screw on tank or pipe	560 707		
	NPT 1 1/4" screw-on adapter with G 1 1/2" external threaded for ELEMENT measuring device connection	PVC-U / FKM, EPDM	To screw on tank or pipe	561 228		
<b>Adapter for conversion of S020 T-fitting to S022 T-fitting</b>						
	Adapter with G 1 1/2" external threaded for ELEMENT measuring device connection	PVC-U / FKM, EPDM	For Bürkert fitting body ≥ DN32 <sup>2)</sup>	560 854		
	Adapter with G 1 1/2" external threaded for ELEMENT measuring device connection	PP / FKM, EPDM	For Bürkert fitting body ≥ DN32 <sup>2)</sup>	561 230		
	Adapter with G 1 1/2" external threaded for ELEMENT measuring device connection	Stainless steel / FKM, EPDM	For Bürkert fitting body ≥ DN32 <sup>2)</sup>	561 233		
<b>INSERTION fitting for connection on pipe</b>						
	Fitting with metric solvent ends connection with G 1 1/2" external threaded for ELEMENT measuring device connection	PVC / FKM	10	559 640		
			15	559 641		
			20	559 642		
			25	559 643		
			32	559 644		
			40	559 645		
			50	559 646		
			65	559 647		
			80	559 648		
			100	559 649		
			Fitting with ASTM solvent ends connection with G 1 1/2" external threaded for ELEMENT measuring device connection	PVC / FKM	15	560 815
					20	560 816
					25	560 817
					32	560 818
40	560 819					
50	560 820					
			65	560 821		
			80	560 822		

<sup>1)</sup> 1 FKM and 1 EPDM seals for the measuring device connection are supplied with each adapter.  
<sup>2)</sup> or analytical true union fitting (DN15 - DN25)

**Ordering chart for adapter/fitting S022**

	Description	Materials Body / Seal <sup>1)</sup>	Type of installation or DN	Item no.
<b>Insertion fitting for connection on pipe</b>				
	Fitting with metric true union connection with spigot and nut for pipe connection and with G 1½" external threaded for ELEMENT measuring device connection	PVC / FKM	15	560 671
			20	560 672
			25	560 673
			32	560 674
			40	560 675
			50	560 676
	Fitting with ASTM true union connection with spigot and nut for pipe connection and with G 1½" external threaded for ELEMENT measuring device connection	PVC / FKM	15	560 691
			20	560 692
			25	560 693
			32	560 694
			40	560 695
	Fitting with saddle with G 1½" external threaded for ELEMENT measuring device connection	PP Body & PVC adapter / EPDM	50	560 700
			65	560 701
			80	560 702
			100	560 703
	110	560 704		
<b>Measuring chamber</b>				
	Measuring chamber with G 1½" external threaded for ELEMENT measuring device connection	Stainless steel 316L - 1.4404	Pipe connection: G 1/2"	563 552

<sup>1)</sup> 1 FKM and 1 EPDM seals for the measuring device connection are supplied with each adapter.

**i Further versions on request**

**Materials**  
PVC-C, PVDF with FKM or EPDM seal

**Ordering chart - accessories for adapter/fitting S022** (has to be ordered separately)

Number on Drawing	Description	Item no.
	Stopper in stainless steel with union nut and O-ring (EPDM and FKM)	562 625
	Stopper in PVC with union nut and O-ring (EPDM and FKM)	562 541
1	FKM O-ring set - for metal adapter	561 654
1	EPDM O-ring set - for metal adapter	561 653
2	FKM O-ring set - for plastic adapter, solvent end fittings and saddle	561 399
2	EPDM O-ring set - for plastic adapter, solvent end fittings and saddle	561 398
3	FKM O-ring set - for plastic adapter or true union fitting DN15 up DN32	431 558
3	FKM O-ring set - for plastic adapter or true union fitting DN40	431 559
3	FKM O-ring set - for plastic adapter or true union fitting DN50	431 560
3	EPDM O-ring set - for plastic adapter or true union fitting DN15 up DN32	431 564
3	EPDM O-ring set - for plastic adapter or true union fitting DN40	431 565
3	EPDM O-ring set - for plastic adapter or true union fitting DN50	431 566

\*\* O-ring to use for holder with lug,  
Flat seal to use for holder with groove (old version)

\*To find your nearest Bürkert office, click on the orange box →

[www.burkert.com](http://www.burkert.com)

In case of special application conditions, please consult for advice.

Subject to alteration.  
© Christian Bürkert GmbH & Co. KG

1305/4\_EU-en\_00895118